

TCM

Versatile All-round Heavy Duty Forklift Trucks



now unveiled!

15~23 ton

FD150H • FD180 • FD200 • FD230



Astonishing Performance

- Increased drawbar pull and gradeability (FD150H)

Drawbar pull (with load)

Gradeability (with load)



- New engine meets-US EPA Tier 2-EU stage II

ISUZU 6BG1T

Total piston displacement : 6.494 lit.

Rated output : 125kW(170ps)/ 2200r.p.m.

Maximum torque : 558N·m(57kg·f)/ 1800r.p.m.



- Lifting speed (FD150H)

Lifting speed(with load)

280 mm/s → 370mm/s



- Sufficient fuel tank

Capacity : 400 lit



Excellent Maneuverability

- Electric 3-speed automatic transmission

Speed changes automatically same as passenger cars.

In case you require no shift change, you may drive only by fixed shift (2 fixed shifts available).

- 1 : First fixed speed
- 2 : Second fixed speed
- D : 3-stage speed shifts



- Easy-to-operate dual-purpose switch with automatic return function (lighting and turn-signal)

Superb Reliability

- Brake line with AIR-DRYER (standard)

Comfortable Cabin

- Consolidated monitor display panel



- Large capacity air-conditioner (optional)

Cooling capacity
3000 kcal/h → 4000 kcal/h



- Delux multi-functional seat (optional)

Suspension · Reclining · Sliding (Fwd & Bwd) Arm-rest · Adjustable for turning as well as up and down



Long Durability

- Wet disc parking brake

Lesser overall maintenance free



<http://www.keiyou.net/>

※ Features and equipment may vary depending on market.

Safety

- Wide forward-view by pillar-less cabin (optional)

10% improved forward-view due to no pillars



- Improved rear-view

Better rear-view by improved appearance of counter-weight



- New electric parking brake system

Electric parking brake operates while ignition key "OFF".



※Features and equipment may vary depending on market.

Load charts

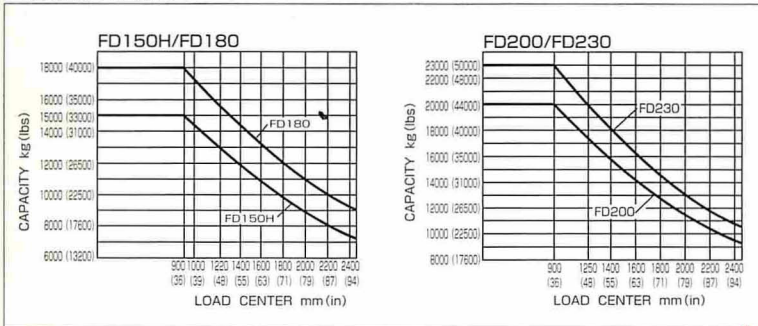

Dimensions

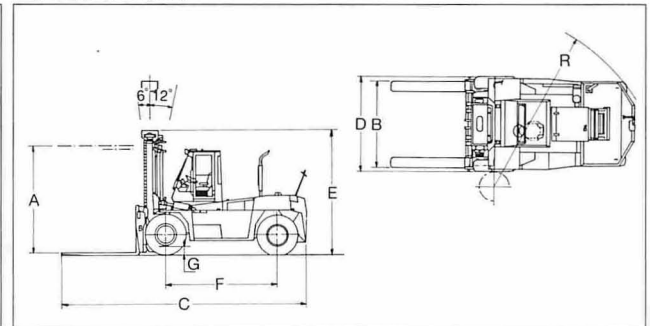

Standard specifications

Model		FD150H	FD180	FD200	FD230
Performance					
Load capacity	kg (lbs)	15000 (33000)	18000 (40000)	20000 (44000)	23000 (50000) / 20000 (44000)
Load center	mm (in)	900 (36)	900 (36)	900 (36)	900 (36) / 1250 (49)
Maximum fork height	mm (in) A	3000 (118.1)	3000 (118.1)	3000 (118.1)	3000 (118.1)
Lifting speed :with load	mm/s (fpm)	370 (72.8)	290 (57.1)	285 (56.1)	240 (47.2)
Mast tilt angle :forward/backward	deg	6/12	6/12	6/12	6/12
Travel speed	km/h (mph)	34 (21.1)	34 (21.1)	34 (21.1)	32 (19.9)
Lateral fork adjustment (outside)	mm (in) B	790 ~ 2750 (31.1 ~ 108.3)	810 ~ 2750 (31.9 ~ 108.3)	810 ~ 2750 (31.9 ~ 108.3)	950 ~ 2750 (37.4 ~ 108.3)
Turning radius (outside)	mm (in) R	5000 (196.9)	5000 (196.9)	5150 (202.8)	5350 (210.6)
Dimensions & Weight					
Overall length	mm (in) C	7165 (282.1)	7205 (283.7)	7205 (283.7)	7985 (314.4)
Overall width	mm (in) D	2970 (116.9)	2990 (117.7)	3060 (120.5)	3060 (120.5)
Overall height :mast	mm (in) E	3290 (129.5)	3540 (139.4)	3570 (140.6)	3580 (140.9)
Wheelbase	mm (in) F	3650 (143.7)	3650 (143.7)	3650 (143.7)	3650 (143.7)
Ground clearance	mm (in) G	320 (12.6)	270 (10.6)	300 (11.8)	290 (11.4)
Total weight	kg (lbs)	22780 (50220)	25170 (55500)	27390 (60400)	30760 (67800)
Engine and Transmission					
Model		ISUZU 6BG1T Diesel Engine			
Piston displacement	lit. (in ³)	6.494 (396.3)			
Rated output /r.p.m.	kW (PS)	125kW (170PS) /2200r.p.m.			
Transmission :type		Automatic power-shift transmission			
:number of speed		3-3 (Fwd/Rvs)			
Tire & Brake					
Tire size		12.00-24-18PR	13.00-24-20PR	14.00-24-24PR (20PR)	14.00-24-24PR
Brake :service		Air-over-hydraulic disc brake			
:parking		Wet disc brake			

TCM products and specifications are subject to change without notice.

Manufactured by



TCM CORPORATION

1-15-5, Nishi-shimbashi 2-chome, Minato-ku
 Tokyo, 105-0003 Japan
 TEL: +81-3-3591-8176
 FAX: +81-3-3591-8152
 URL: <http://www.tcmglobal.net/>

Distributed by

<http://www.keiyou.net/>